

## Flat Section Spring Washer

**Material:** Mild Steel

**Class Grade:** Low Tensile Grade 2

**Corrosion Protection Level:** Moderate

**Finish:** Zinc Plated

**Standard:** ANSI B18.22.1

**System Of Measurement:** Imperial

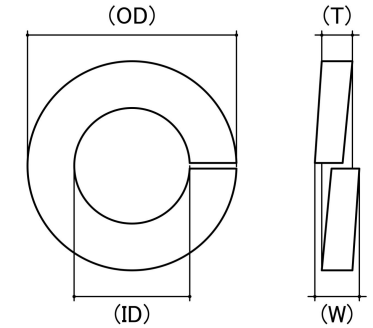

*CAD drawings shown for graphic representation only.\**

Industry Size (inches)	Inside Dimension (ID) (mm)		Outside Dimension (OD) (mm)	Width (W) (mm)	Thickness (T) (mm)	sku (qfind)
	Min	Max	Nom	Nom	Nom	
1/8	3.10	3.40	6.00	1.20	0.80	71P18
5/32	4.10	4.50	7.55	1.60	1.20	71P532
3/16 (#10-24)	5.10	5.50	9.00	1.60	1.20	71P316
1/4	6.10	6.70	12.00	2.40	1.60	71P14
5/16	8.00	8.50	15.00	3.20	2.00	71P516
3/8	9.50	9.90	17.50	3.20	2.40	71P38
7/16	11.30	-	20.00	4.00	4.00	71P716
1/2	12.20	13.00	22.00	4.80	3.20	71P12
9/16	14.20	14.70	24.00	4.80	3.20	71P916
5/8	16.20	17.00	27.00	5.60	4.00	71P58
3/4	19.10	19.50	32.00	6.35	4.75	71P34
7/8	22.30	24.00	37.00	6.35	5.50	71P78
1	24.50	26.50	42.00	7.90	6.35	71P1

**Disclaimer:**

Dimensional data and technical information was obtained from publically available sources and not acquired through standard agencies. It has been completed and compiled for reference purposes only; where discrepancies are found they are subject to change without notice. Bolt & Nut Australia makes no warranties or representations regarding the accuracy and validity of the compiled information and data. Contact the relevant standard authorities for accurate and detailed information.

\* CAD drawings may not reflect diameter, thread length or overall length.